

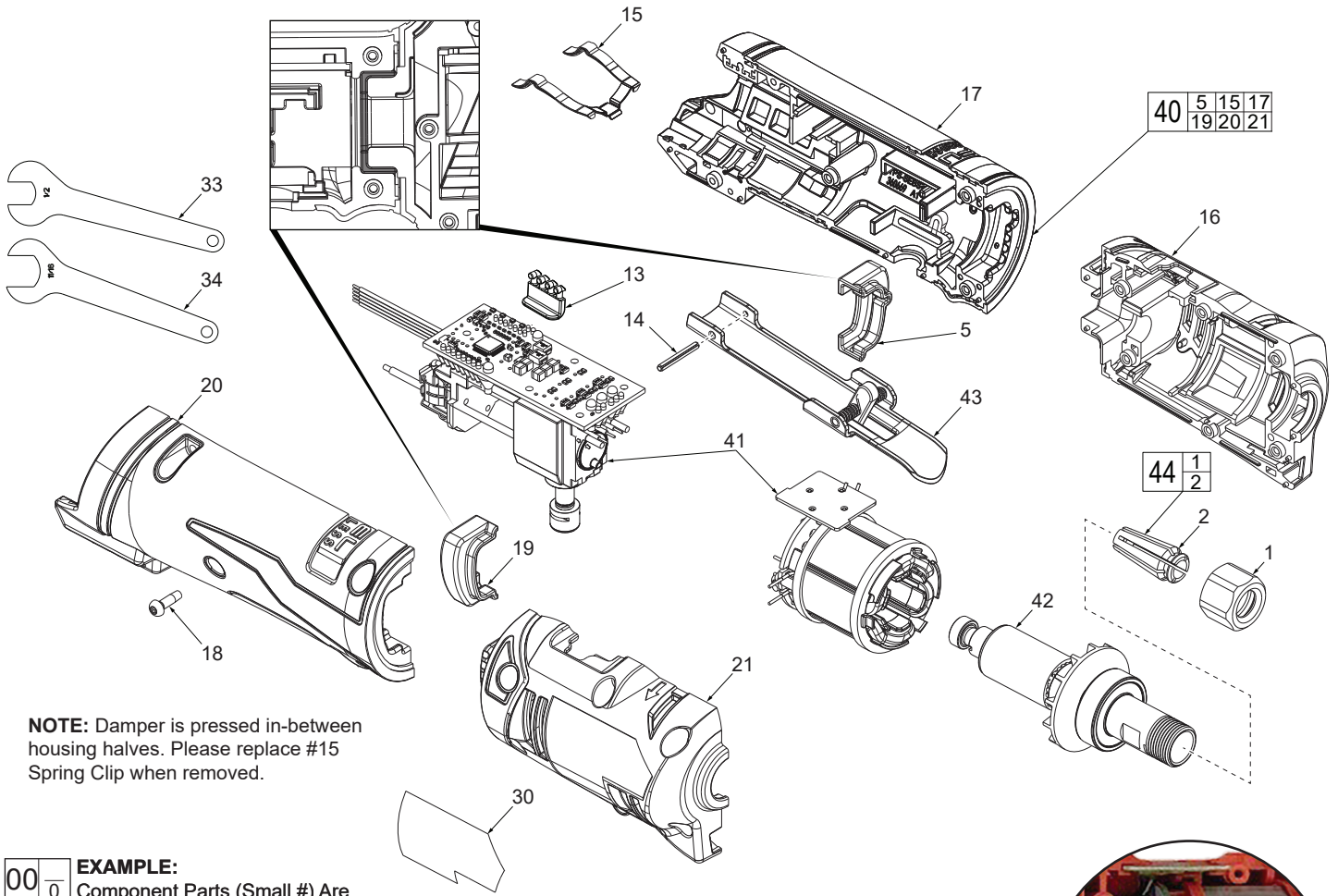

SERVICE PARTS LIST

SPECIFY CATALOG NO. AND SERIAL NO. WHEN ORDERING PARTS		REVISED BULLETIN	DATE
M12 FUEL™ Straight Die Grinder			Sep. 2019
MODEL NO. M12FDGS-0	2486-20	WIRING INSTRUCTION	



NOTE: Damper is pressed in-between housing halves. Please replace #15 Spring Clip when removed.

EXAMPLE:

00	0
----	---

 Component Parts (Small #) Are Included When Ordering The Assembly (Large #).

Install the electronics assembly, route wires through wire traps and channels as shown. Be sure all components are seated squarely and firmly in place. Be sure there is no interference when installing the housing covers (20, 21).

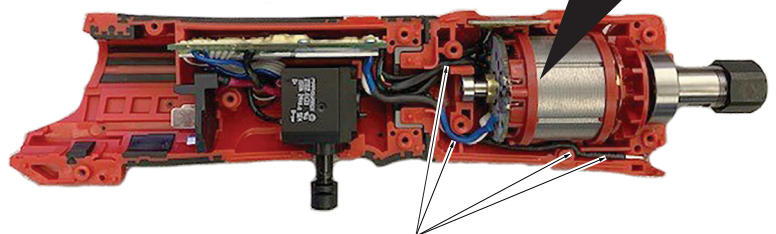
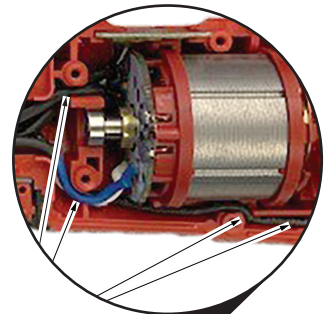

Wire Traps or Channels

SCREW TORQUE SPECIFICATIONS			
FIG.	WHERE USED	SEAT TORQUE	
		(KG/CM)	(IN/LBS)
18	Housing Cover Head	7-9	6.0-7.8
18	Housing Cover Grip	7-9	6.0-7.8