

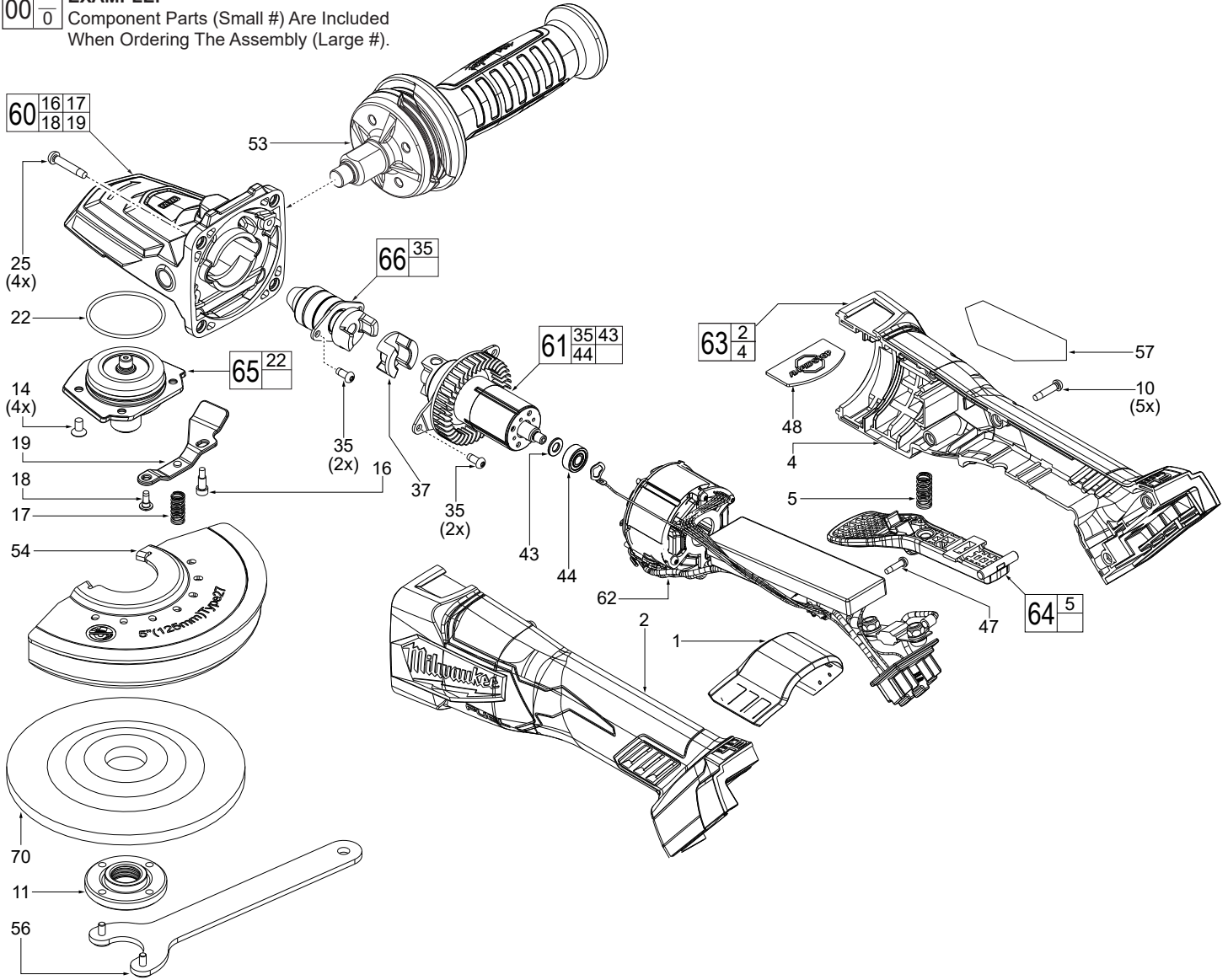

# SERVICE PARTS LIST

SPECIFY MODEL NO. AND SERIAL NO. WHEN ORDERING PARTS		REVISED BULLETIN	DATE
M18 FUEL™ Flat Head Braking Angle Grinder w/ Paddle Switch			Mar. 2021
MODEL NO. M18FAGF125XPDB-0	2886-20	WIRING INSTRUCTION <b>SEE PAGE 2</b>	

**EXAMPLE:**  
 00 0 Component Parts (Small #) Are Included  
 When Ordering The Assembly (Large #).



**\*LUBRICATION NOTE:**  
 When servicing the Gear Case Assembly, 90-95% of the old grease must be removed prior to new grease being added.

**FIG. LUBRICATION\***  
 56 Type 'J' Grease, No. 49084220, 1 lb. can. Place approximately 5 grams (.176 oz.) in gearcase cavity, being sure to completely coat all teeth of bevel pinion and surrounding area.

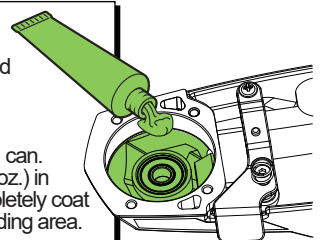

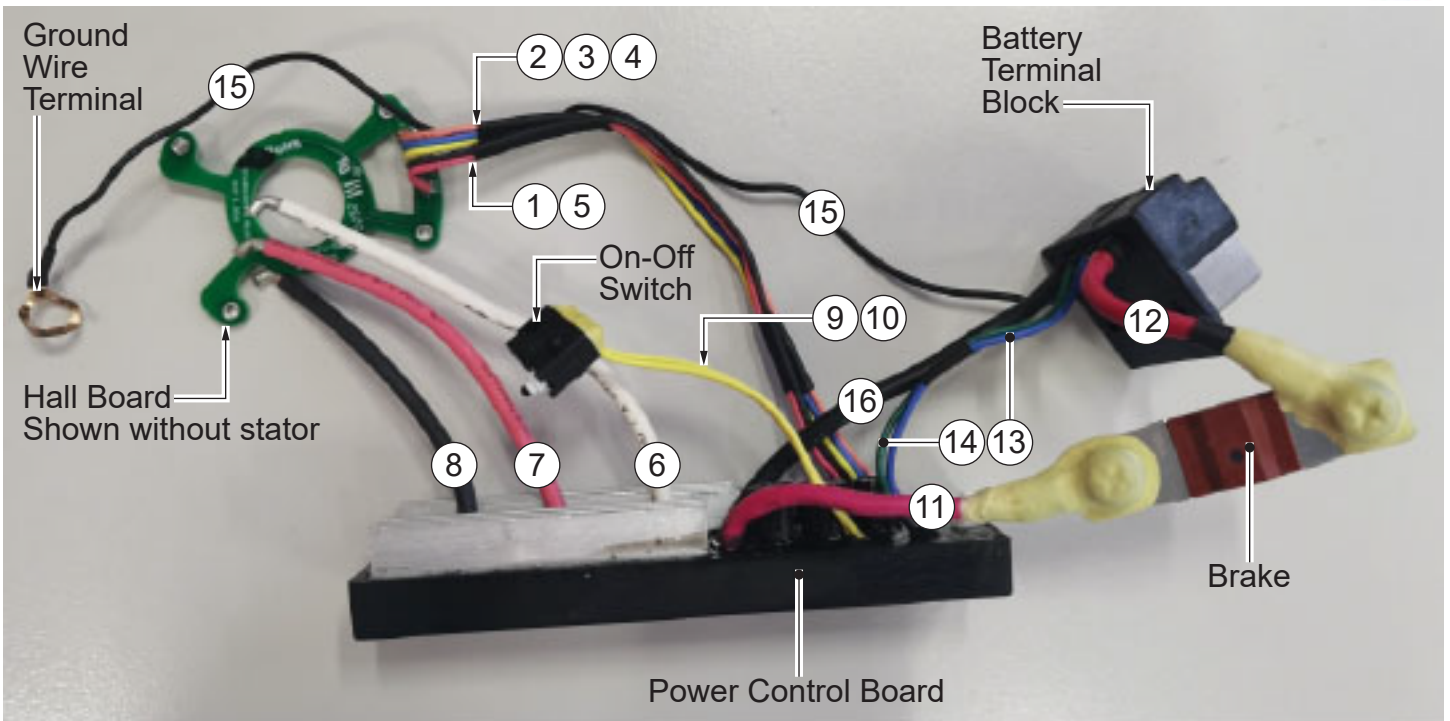

Wire	Color	Orientation
1	Red	From Hall Board to Power Control Board
2	Pink	From Hall Board to Power Control Board
3	Blue	From Hall Board to Power Control Board
4	Yellow	From Hall Board to Power Control Board
5	Black	From Hall Board to Power Control Board
6	White	From Power Control Board to Stator
7	Red	From Power Control Board to Stator
8	Black	From Power Control Board to Stator
9	Yellow	From Power Control Board to On-Off Switch
10	Yellow	From Power Control Board to On-Off Switch
11	Red	From Power Control Board to Brake
12	Red	From Battery Terminal Block to Brake
15	Black	HV Wire. From Battery Terminal Block to Gearcase
16	Black	From Power Control Board to Battery Terminal Block

As an aid to reassembly, take notice of wire routing and position in wire guides and traps while dismantling tool.

Be sure that all components of the electronics kit are seated firmly and squarely in the housing recesses.

Avoid pinched wires, be sure that all wires and sleeves are pressed completely down in wire guides and traps.

Prior to securing the housing cover onto the housing support, be sure that there are no interferences.

Before installing the battery, check for proper functionality of paddle trigger.

Install battery and depress paddle trigger to assure tool is operating properly.