

Position	Amount	Type number	Description	PG
1	7	141116020	Self-tap fill h screw	12
2	1	343393040	Housing w.cover w/o flange	24
3	1	143192260	O-ring	12
4	1	143114740	Ball bearing, 8x22x7	22
5	1	343254370	Condenser	10
6	1	343254360	Choke	13
7	2	141116970	Fillister head screw	12
8	1	343408310	Electronic switch	30
9	1	344101140	Cable sleeve	13
10	1	344492040	Cable with plug,230V	29
11	1	317003390	Motor 230V compl.	40
12	1	316035030	Brush set	21
13	4	344091420	Rubber plug	10
14	1	141156000	Washer	10
15	1	143112030	Ball bearing, 15x32x9	26
16	4	141120070	Fill. head screw	10
17	1	330001730	Fan	29
18	1	316021240	Carrier cpl.	28
19	1	141180710	Ring	14
20	1	343392440	Brakering holder	14
21	1	344097450	Brake ring	17
22	4	141123420	Self-tapp. counters. screw	10
23	1	339160410	Backing plate cpl.	27
24	1	141122300	Cap screw	10
25	1	343254350	Choke	13
26	1	338048010	Rating plate	10
27	1	315416130	Bearing flange	17
28	2	338120380	Metabo label	10
29	1	143194110	O-ring	10
31	1	344161530	Hexagonal key	12
32	1	316040160	Dust collector cartridge	25
880	1	344131030	Grease 50Gr 1,8oz	22
1001	1	338504480	Diagram	

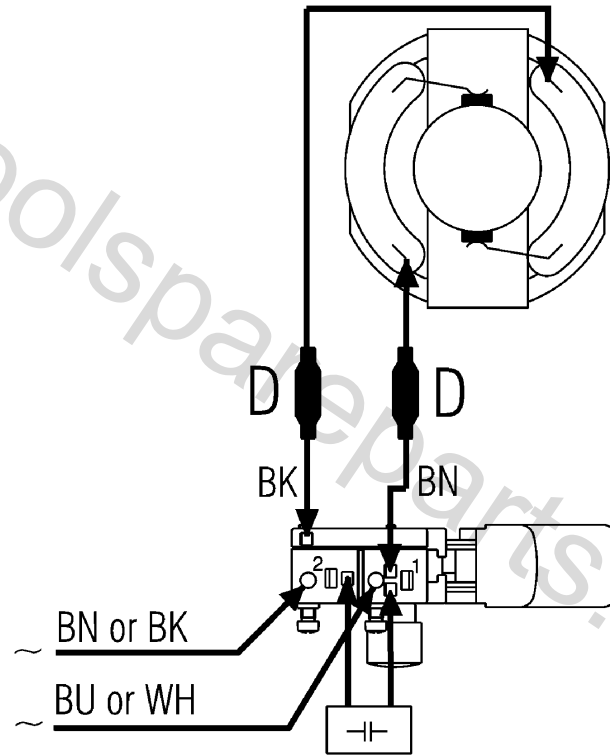

Circuit Block Diagram

